

Enhancing the Computing Efficiency of Power System Dynamic Analysis with PSS_E

Ke Meng, Zhao Yang Dong, Kit Po Wong*

Department of Electrical Engineering
The Hong Kong Polytechnic University
Hung Hom, Kowloon, Hong Kong

{eekemeng, eezydong, eekpwong}@polyu.edu.hk

* also an Adjunct Professor with the School of Electrical, Electronic, and Computer Engineering, University of Western Australia, Perth, Australia

Abstract—Power system simulator for engineering (PSS_E) has gained great success in power energy industry for its powerful simulation and analysis functions. Along with market deregulation, power system planning and stability analysis warrants more effective and fast techniques due to the ever expanding large-scale interconnection of power networks. Running large-scale system multiple case studies on PSS_E will cost intensive time and efforts. In this paper, we accelerate PSS_E dynamic simulations with EnFuzion based distributed computing technique. This approach is proved to be effective by testing with 39-bus New England power system “n-1” and “n-1-1” contingency analysis. The results show that the simulation process can be speeded dramatically and the total elapsed time can be reduced proportionally with the increase of computer nodes.

Keywords—Distributed computing, EnFuzion, Power System Dynamic simulations, PSS_E

I. INTRODUCTION

The power industry has undergone significant changes through restructuring across the world since the 1990s. Along with deregulation, power systems presently face more severe challenges from the ever expanding large-scale interconnection of power networks. Some power system problems have become difficult to analyze with traditional approaches. Many exterior constraints now need to be taken into consideration. All of such means rapid increase in computing requirement for system operations particularly in real time dynamic security assessment (DSA). One consequence is that more advanced and efficient power system analysis methods are required in the deregulated environment. PSS_E, an integrated, interactive program from Siemens Power Technologies Inc. (PTI), provides a variety of useful functions for power system analysis, namely the power flow, faults analysis, and dynamic simulations [1]. However, when running large scale power system multiple case studies with PSS_E dynamic simulations, it will cost lots of time and efforts. Although we can manually split a program into several separate jobs which then can be run simultaneously on multiple computers, the process was labor intensive and susceptible to error [2]. Fortunately, the computational power of modern computers and the application of web technology have facilitated the effective employment of new techniques to improve computational efficiency.

Distributed computing, a form of parallel computing, is one of the direct results of the need to meet large-scale and complex computational demand common in many fields. It involves the integration, cooperation, and management of network computers. The main goal of distributed computing system is to connect users and resources in a transparent, open, and scalable way, which ideally is drastically more powerful than many combinations of stand-alone computers [3]. Furthermore, nowadays distributed computing projects have been designed to use the large number of volunteers' computers of all over the world, via the Internet, to solve complex problems, which are impossible for anyone computer or person to solve in a reasonable amount of time. A variety of distributed computing projects have grown up in recent years for research and commercial purposes [4].

EnFuzion, a distributed computing tool developed by Axceleon [5], has been used in a wide range of areas, such as financial industry, bioinformatics, electronics design, computer graphics, and power systems [2]. Key outstanding features of EnFuzion can be summarized as follows: strong robustness, high reliability, efficient network utilization, intuitive GUI interface, multi platform support, and extensive administrative tools [2].

In this paper, a computing platform is proposed for power system contingency analysis with PSS_E dynamic simulations aiming at achieving higher computational efficiency so as to enhance the computing capability of PSS_E in power system research in cases where large scale power systems and/or multiple analysis are needed. The paper is organized as follows, after the introduction section; the EnFuzion technique is briefly reviewed for completeness, followed by the detailed steps of the proposed approach. Then case studies using the 39-Bus New England power system are given. Conclusions and further developments are given in the last section.

II. DISTRIBUTED COMPUTING

Distributed computing is a science which solves a large complex problem by giving small parts of the problem to many computers via network to solve and then combining the solutions together into a solution for the problem.

The power of EnFuzion can be directed through its feature for efficient computers managements and easy programs implementations. It provides users an easy and friendly environment to execute programs over multiple computers. It allows users to specify experiment parameters and monitor the whole process using simple Java based GUI. After specify the input files and commands by user, the EnFuzion can produce jobs list, disperse them to separate computers, monitor whole progress, and then reassemble the results from each of these batch runs automatically. Jobs could be dispatched to computers over a local area network or over the Internet. To the users themselves, it spears that the programs are executing on their own machines with faster speed.

There are three kinds of nodes in the EnFuzion environment, namely the user nodes, control node, and worker nodes, which are interconnected with high-speed networks. A simple topology structure is shown in Fig. 1.

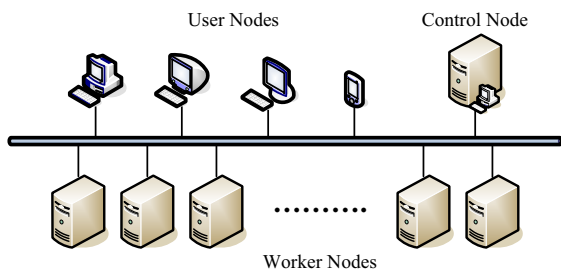

Figure 1. Structure of EnFuzion Topology

The typical users-control-workers system works as illustrated in Table I.

TABLE I. ENFUZION WORK STEPS

How does EnFuzion work?	
1.	User nodes submit jobs to control node
2.	Control node manages and assigns jobs to worker nodes
3.	Worker nodes execute jobs until completion
4.	Control node reassemble and store results from worker nodes
5.	User nodes receive results from control node

Detailed functionalities and principles of EnFuzion can be found from the Axceleon website [2]. A platform has been developed by the authors to enable control and execution of PSS_E commands through EnFuzion - see Fig 2. In the next section, we will test this approach with contingencies analysis on PSS_E.

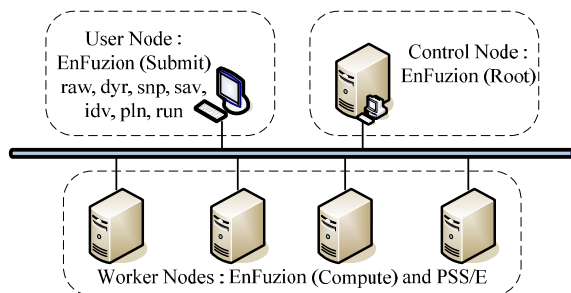

Figure 2. The Distributed Computation based PSS/E Simulation Platform

III. POWER SYSTEM CASE STUDY

The primary objective of case study is to test how distributed computation can speed up PSS_E simulations. The contingency considered here is when a power system is subjected to sufficiently large disturbances, and then the relevant transmission lines will be tripped to clear the faults. This research results may be used as complementary database to SCADA system for power system stability analysis – as shown in Fig. 3.

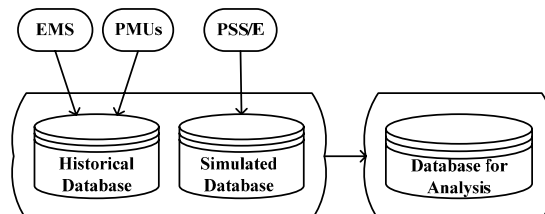

Figure 3. Database for Stability Analysis

One of the main objectives of this study is to simulate the cascading failure scenarios. It is the prevention of cascading failure that now attracts so much concern because it is not only closely related to the security of the power system itself, but also to the national security more generally. The generic scenario of cascading failures [6], [7] can be summarized as depicted in Fig. 4, [8].

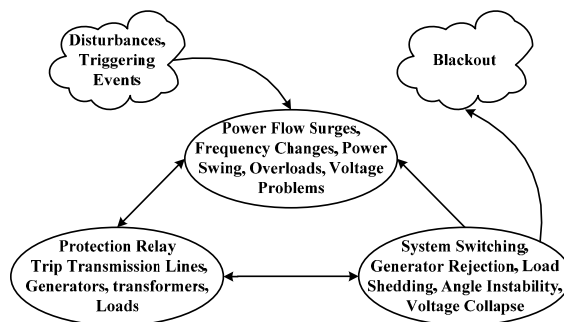

Figure 4. Generic scenario of a cascading blackout

A. 39-Bus New England Power System

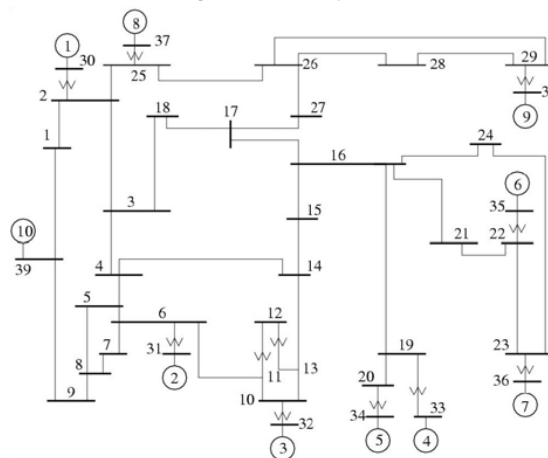

Figure 5. The 39-Bus New England System

The proposed methods are tested within the New England 39 bus power system that is depicted in Fig. 5. This is a regional power system that serves the six states of Maine, Connecticut, Massachusetts, New Hampshire, Rhode Island, and Vermont. Currently, it includes more than 350 separate generators and more than 8,000 miles of transmission lines [9].

B. Data Generation

Following a system contingency, a power system might be subject to a sudden increase of reactive power demand. This can be met by the reactive power reserves carried by the generators and compensator. However, it is possible that because of cascading events, the additional reactive power demand may lead to a voltage collapse. Our studies will provide very useful data sets for power system stability analysis. From the data, we can identify the key regions or components that are most sensitive to disturbances; identify the key transmission line relay that is not sensitive to disturbances; study the impact on power swing on the needs for power swing blocking and out of step relays in the system; and cascading failure analysis.

Case 1: The situations considered in this case include four load types (LT), 34 fault locations (FL), one fault type (FT), and one fault clearing time (CT). The three-phase fault zero impedance to ground was considered. The creation of the system fault was followed by removing one branch in the power system. The total simulation time for each case is 5 seconds, with the initial condition period being 1 second followed by the fault period of 0.1 seconds. The voltage recovery stage is achieved after the fault has been cleared, which is after a period set to 1 second in the study. The next period is the swing period, during which the voltage collapses, oscillates, or returns to a new level. In the process, 136 ($4 \times 34 \times 1 \times 1$) output data files are obtained finally in the form of PSS_E channel files. The fault simulation scenario is depicted in Fig. 6.

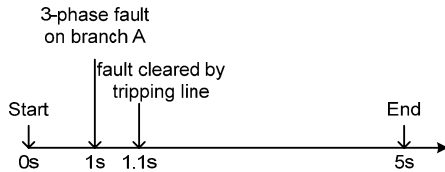

Figure 6. Faults Simulation Scenario Example of Case 1

Case 2: The situations considered in this case include four load types (LT), 34 first fault locations (FL), 33 second fault locations (SL), one fault type (FT), and one fault clearing time (CT). The three-phase fault zero impedance to ground was considered. The creation of the first system fault was followed by removing one branch in the power system, and then the second fault occurred in one of the remaining 33 transmission lines. The total simulation period for each case is 10 seconds, with the initial condition period being one second followed by the first fault period of 0.1 seconds. The voltage recovery stage is achieved after the fault has been cleared, which is after a period set to 1 second in the study. The next period is the swing period, during which the voltage collapses, oscillates, or returns to a new level. Then, the second fault was created at five seconds, followed by 0.1 seconds of fault period, one second of recovery stage, and the swing period. In the process, 4,488 ($4 \times 34 \times 33 \times 1 \times 1$) output data files are obtained finally in the

form of PSS_E channel files. The fault simulation scenario is depicted in Fig. 7.

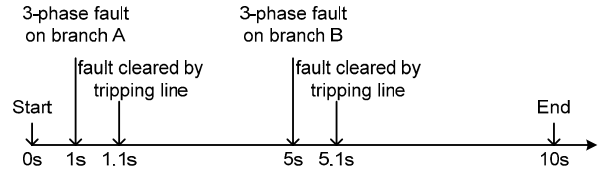

Figure 7. Faults Simulation Scenario Example of Case 2

The specific fault locations and the relevant branch numbers are represented in Table II. Four different types of load models were considered and these are detailed in Tables III.

TABLE II. LOAD MODEL TYPES

Load Types	Large Motor (%)	Small Motor (%)
LT01	10	20
LT02	30	40
LT03	50	30
LT04	75	10

TABLE III. FAULT LOCATIONS VS. BRANCH NUMBER

Name	Branch	Name	Branch	Name	Branch
FL01,SL01	01-02	FL02,SL02	01-39	FL03,SL03	02-03
FL04,SL04	02-25	FL05,SL05	03-04	FL06,SL06	03-18
FL07,SL07	04-05	FL08,SL08	04-14	FL09,SL09	05-06
FL10,SL10	05-08	FL11,SL11	06-07	FL12,SL12	06-11
FL13,SL13	07-08	FL14,SL14	08-09	FL15,SL15	09-39
FL16,SL16	10-11	FL17,SL17	10-13	FL18,SL18	13-14
FL19,SL19	14-15	FL20,SL20	15-16	FL21,SL21	16-17
FL22,SL22	16-19	FL23,SL23	16-21	FL24,SL24	16-24
FL25,SL25	17-18	FL26,SL26	17-27	FL27,SL27	21-22
FL28,SL28	22-23	FL29,SL29	23-24	FL30,SL30	25-26
FL31,SL31	26-27	FL32,SL32	26-28	FL33,SL33	26-29
FL34,SL34	28-29				

C. Programming

The iPLAN code for PSS_E can be generated with our Matlab GUI, shown in Fig. 8.

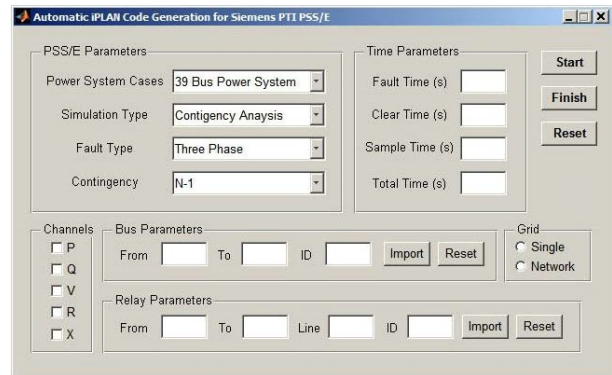

Figure 8. Automatic iPLAN Code Generation for PSS_E

For each of the 136 and 4,488 output data files, the P, Q, V, R, and X data at each of the 17 load buses are extracted and saved. Therefore, 2,312 (136×17) and 76,296 ($4,488 \times 17$) sets

of sample files are obtained and saved in Excel format, respectively. This job can be finished with our other PSS_E and Matlab programs.

TABLE IV. DETAILED ENFUZION EXECUTION STEPS ("N-1", LT01)

EnFuzion Execution Steps and Code (psses1 LT01.run)	
1.	% Set System Paths %
2.	% Nodes Initiation, Copy Files to Remote Nodes % <i>task nodestart</i> <i>copy NE_LT01.snp node:.</i> <i>copy NE_LT01.sav node:.</i> <i>copy NE_LT01.dyr node:.</i> <i>copy psses1_LT01.idv node:.</i> <i>endtask</i>
3.	% Job Execution % % -Substitute Parameter Values in PSS_E idv File % % -Execute PSS_E % % -Reassemble Result Files % <i>task main</i> <i>node:substitute psses1_LT01.idv input.idv</i> <i>node:execute psses430 -gnikool off -inpdev input.idv</i> <i>copy node:NE_LT01_FL.out NE_LT01_FL\$cycles.out</i> <i>endtask</i>
4.	% Variables Index % <i>variable cycles index 0 list.....</i> <i>variable Fault_Bus index 1 list.....</i> <i>variable Fault_Branch index 2 list.....</i> <i>indexcount 3</i>
5.	% Jobs List %

D. Results and Analysis

Case 1: Based on the data obtained through 3 trials, the comparisons of average computational cost are represented in Fig. 9 and Table V. The simulation jobs take approximately 73 minutes and 3 seconds on single computer with iPLAN program, while the same tasks are completed in 11 minutes and 15 seconds with idv code, which means that the idv method is more efficient than the iPLAN approach. Furthermore, the computational cost can be reduced to only 1 minutes and 45 seconds by collaboration of 4 nodes with EnFuzion technique. We can also observe that, by increasing n times of nodes in the processing collaboratively, the efficiency is achieved more than n times. This is because of some nodes (Core 2CPU) can run two jobs simultaneously, which can speed up the PSS_E dynamic simulation process dramatically.

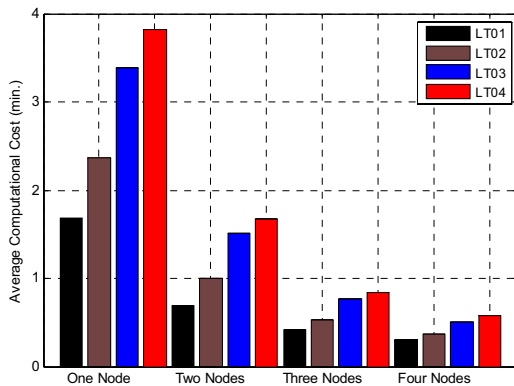

Figure 9. N-1 Contingency Analysis Computational Cost Comparisons

TABLE V. COMPUTATIONAL COST COMPARISONS (MM:SS)

Load Types	Single (iPLAN)	EnFuzion Nodes (idv)			
		One	Two	Three	Four
LT01	14:45	01:41	00:41	00:25	00:18
LT02	17:53	02:22	01:00	00:32	00:22
LT03	18:30	03:23	01:31	00:46	00:30
LT04	21:55	03:49	01:40	00:50	00:35
Total	73:03	11:15	04:52	02:33	01:45

Case 2: Based on the data obtained through 3 trials, the comparisons of average computational cost are represented in Fig. 10 and Table VI. The simulation jobs take approximately 187 hours 51 minutes and 9 seconds on single computer with iPLAN program, while the same tasks can be reduced to only 1 hour 37 minutes and 10 seconds by collaboration of 4 nodes with EnFuzion technique.

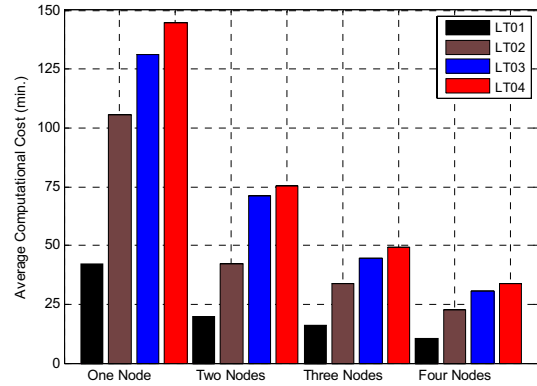

Figure 10. N-1-1 Contingency Analysis Computational Cost Comparisons

TABLE VI. COMPUTATIONAL COST COMPARISONS (HH:MM:SS)

Load Types	Single (iPLAN)	EnFuzion Nodes (idv)			
		One	Two	Three	Four
LT01	16:14:04	00:42:04	00:19:46	00:15:58	00:10:38
LT02	43:09:21	01:45:25	00:42:01	00:33:55	00:22:38
LT03	57:30:12	02:11:14	01:11:13	00:44:25	00:30:19
LT04	70:57:32	02:24:34	01:15:20	00:48:59	00:33:35
Total	187:51:09	07:03:17	03:28:20	02:23:17	01:37:10

IV. CONCLUSION

Power system simulation both dynamic and static is the essential requirement for power system operation and control. In view of the increasing complexity in power system itself and the computational tasks required, the computational efficiency of specialty software used for such purpose has become a primary concern for the power industry. PSS_E is one of the main simulation tools for the power industry across the world used for system analysis. Traditionally, PSS_E has mainly been used in a single computing node. In this paper, a distributed computing based platform had been developed and presented which significantly improved the computing efficiency for PSS_E based system analysis. Case studies using the New England test system clearly show the improvement and potential of

this approach. It can provide a powerful tool for the power industry in their routine work involving PSS_E.

REFERENCES

- [1] PSS_E™ 31.0 User Manual, SIEMENS PTI, Dec. 2007.
- [2] Axceleon website, <http://www.axceleon.com>.
- [3] H. Attiya and J. Welch, *Distributed Computing: Fundamentals, Simulations, and Advanced Topics*, Wiley-Interscience, 2004.
- [4] List of distributed computing projects, [Online] http://en.wikipedia.org/wiki/List_of_distributed_computing_projects.
- [5] EnFuzion 8.0 User Manual, [Online] <http://www.csse.monash.edu.au/cluster/enfman80/book1.htm>.
- [6] IEEE PES CAMS Task Force on Understanding, Prediction, Mitigation and Restoration of Cascading Failures, "Initial review of methods for cascading failure analysis in electric power transmission systems" Proc IEE PES General meeting 2008. (I. Dobson (task lead), Z.Y. Dong, B. Gou, D. Hawkins, H. Huang, M. Joung, D. Kirschen, F.X. Li, J. Li, Z.Y. Li, C.C. Liu, L. Mili, S. Miller, R. Podmore, K. Schneider, K. Sun, D. Wang, Z.G. Wu, P. Zhang (task force chair), W.J. Zhang, X.P. Zhang).
- [7] IEEE PES CAMS Task Force on Understanding, Prediction, Mitigation and Restoration of Cascading Failures, (member of the taskforce), "Vulnerability Assessment for Predicting Cascading Failures in Electric Power Transmission Systems", (H. Huang (lead) I. Dobson, Z.Y. Dong, B. Gou, D. Hawkins, M. Joung, D. Kirschen, F.X. Li, J. Li, Z.Y. Li, C.C. Liu, L. Mili, S. Miller, R. Podmore, K. Schneider, K. Sun, D. Wang, Z.G. Wu, P. Zhang (task force chair), W.J. Zhang, X.P. Zhang).
- [8] R.C. Hardiman, M. Kumbale, and Y.V. Makarov, "An advanced tool for analyzing multiple cascading failures," presented at the 8th Int. Conf. Probabilistic Methods Applied to Power Systems, Ames, IA, 2004.
- [9] The website of New England Independent System Operator: www.iso-ne.com.